

RAINMOON Concealed ceiling installation box -

35 610 970 90

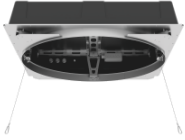

- concealed rough parts
- Rain panel with 2 different spray modes
- AQUACIRCLE RAIN: Circular rain curtain, max. flow rate 6.8 l/min (at 3 bar)
- TEMPEST RAIN: Natural rain, max. flow rate 5 l/min (at 3 bar)
- Ceiling installation enclosure 1356 x 1356 x 290 mm
- Opening diameter 1252 mm
- Ceiling construction with adequate structural strength for the permanent attachment of the device (weight: 57.5 kg / 127 lbs. (US)). M8 threaded bolts (minimum strength: 2000 N) are required to secure the ceiling module

RAINMOON Concealed ceiling installation box -

35 610 970 90

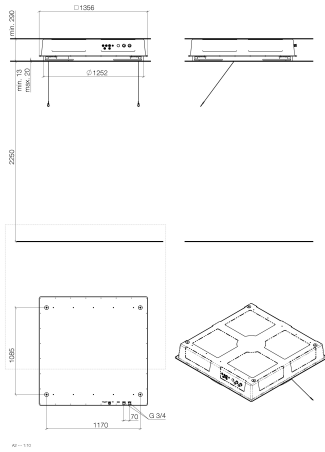

Certificates

LGA_29445.

RAINMOON Concealed ceiling installation box -

35 610 970 90

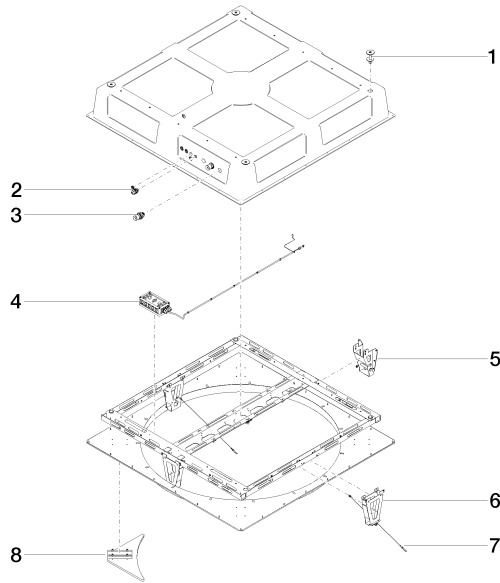

Spare parts list

No.	Item Number	Name	Quantity used	Delivery time
1	04 24 03 287 02 90	fixing set	4	60
2	90 10 01 089 00 90	accessories	1	2
3	90 24 03 286 00 90	connection	3	2
4	90 10 01 192 00 90	electronic accessories	1	2
5	90 17 20 205 00 90	holder	1	2
6	90 17 20 209 00 90	holder	1	2
7	90 21 50 007 00 90	accessories	2	2
8	90 17 20 215 00 90	end stop	4	2